

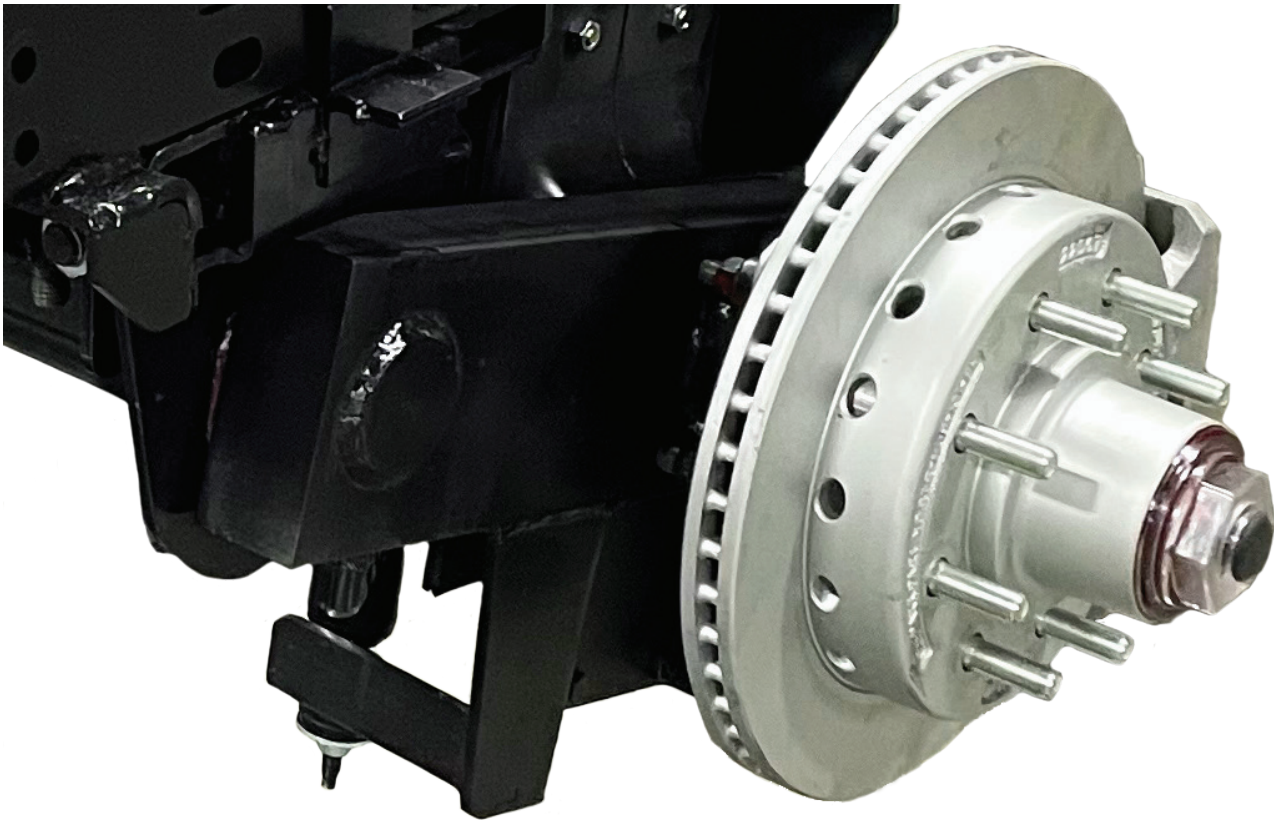

INDEPENDENT SUSPENSION

OWNER'S MANUAL



Above. Beyond. Always.

574.293.1581
www.MORryde.com



Above. Beyond. Always.

574.293.1581
www.MORryde.com

INDEPENDENT SUSPENSION SYSTEM

OWNER'S MANUAL

CONTENTS

Introduction	3
7K and 8K Replacement Parts List.....	4
Service.....	5
Rubber Shear Spring Inspection, Deflection and Replacement.....	6
Alignment Procedures.....	8
Shock Absorber Maintenance and Replacement	10
Replacement of Beam Assembly.....	11
Torque Chart.....	12
Brake Control Setup.....	12
Limited Warranty.....	13

INDEPENDENT SUSPENSION SYSTEM

INTRODUCTION

The MORryde Independent Suspension system, or I.S. system, uses 100% natural rubber springs to support the trailer weight and absorb road shock. By absorbing the shock, the rubber provides a much smoother towing experience than steel leaf springs. With the new MORryde I.S. system, there are no more broken leaf springs! The towing is virtually hassle-free with the smoothest towing available for 5th wheels and travel trailers.

The primary benefits that you can expect from the MORryde I.S. system are:

SMOOTHER TOWING - The MORryde suspension has up to 2 1/2 times the suspension travel of leaf springs or rubber axles, allowing it to better absorb road shock.

IMPROVED TOWABILITY - The MORryde suspension is designed to “block” body roll, improving the cornering and stability of the tow vehicle and trailer combination.

AUTOMOTIVE STYLE ALIGNMENT - A MORryde first! You can manage your tire wear through toe and camber adjustments, a feature no other towable suspension offers.

HEIGHT ADJUSTABILITY - The MORryde suspension can be adjusted easily to accommodate different tow heights and compensate for side-to-side load variations.

PROVEN DURABILITY - The MORryde suspension has undergone strenuous testing to prove its durability. The result? No more broken leaf springs!

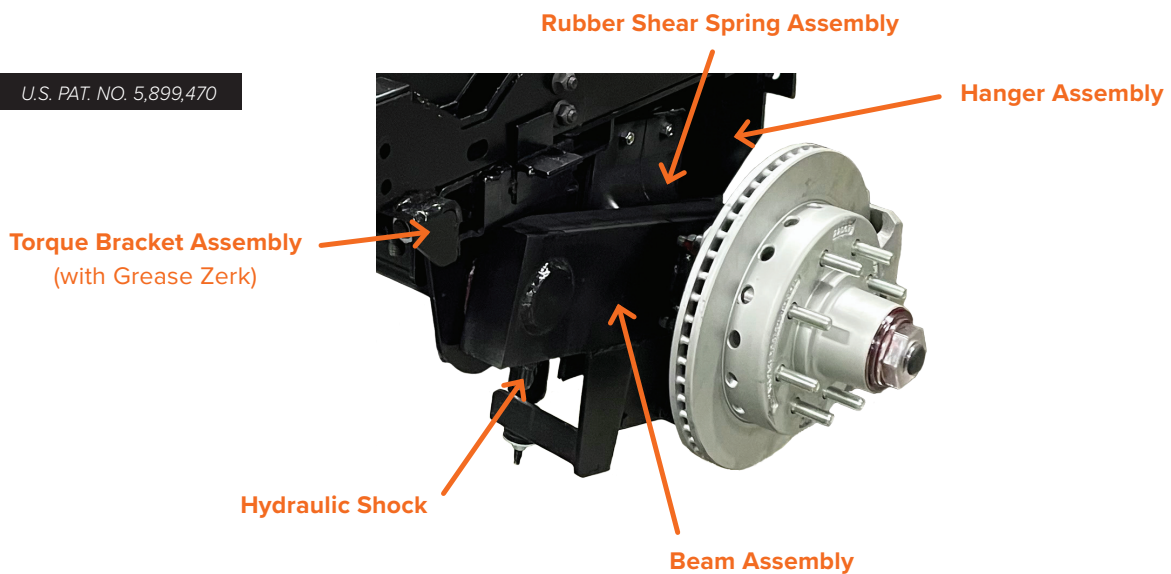

Above. Beyond. Always.

574.293.1581
www.MORryde.com

INDEPENDENT SUSPENSION SYSTEM

7K AND 8K REPLACEMENT PARTS LIST

Qty	Part Number	Description
Kodiak Supplied 4/30/22 and prior		
1	- UO138-081	9/16" STUD BRAKE KIT
2 per kit	- UO138-013	- ROTOR/HUB
2 per kit	- UO138-070	- CALIPER
2 per kit	- UO138-061 (4 bolt) / UO138-063 (5 bolt)	- MOUNTING BRACKET
2 per kit	- UO138-064	- CAP
Hydrastar Supplied 4/30/22 to 6/16/23		
1	UO138-119	9/16" STUD BRAKE KIT
2 per kit	- UO138-121	- ROTOR/HUB
2 per kit	- UO138-007	- CALIPER
2 per kit	- UO138-009 (4 bolt) / UO138-008 (5 bolt)	- MOUNTING BRACKET
2 per kit	- UO138-122	- CAP
DeeMaxx Supplied 6/19/23 and forward		
1	UO138-099	9/16" STUD BRAKE KIT
2 per kit	- UO138-114	- ROTOR/HUB
2 per kit	- UO138-115	- CALIPER
2 per kit	- UO138-116 (4 bolt) / UO138-141 (5 bolt)	- MOUNTING BRACKET
2 per kit	- UO138-064	- CAP
2	UO138-034	INNER BEARING 25580 (TIMKEN)
2	UO138-029	OUTER BEARING 02475 (TIMKEN)
2	UO138-106	INNER RACE 25520 (TIMKEN)
2	UO138-105	OUTER RACE 02420 (TIMKEN)
2	UO138-101	SPINDLE WASHER
2	UO138-084	EZ LUBE SPINDLE NUT RETAINER CLIP
2	UO138-434	EZ LUBE SPINDLE JAM NUT
2	UO138-033	2.25" SEAL (010-036-00)
8	UO116-381	4-BOLT MOUNTING BRACKET NUT
8	UO115-1042	4-BOLT MOUNTING BRACKET BOLT
1	UO138-139 (DeeMaxx)	BRAKE PADS
1	UO138-086 (Kodiak & Hydrastar)	BRAKE PADS
2	UO109-030	SHOCK ABSORBER (MONROE - 555001)

INDEPENDENT SUSPENSION SYSTEM

SERVICE PROCEDURES

NOTE: All service procedures must be performed while the vehicle is supported at the frame with appropriately rated safety stands and jacks.

Maintenance on the I.S. system is minimal. For service information regarding braking systems or bearing options on your trailer, please consult the owner's manual provided by the brake manufacturer.

BEARING & TORQUE BRACKET SERVICE

How often should I re-pack my bearings?

Every 12,000 to 15,000 miles or 1 time a year; whichever comes first.

How often should I grease my torque brackets?

Every 10,000 miles or 1-2 times a year.

What kind of grease do you use for the bearings and the torque brackets?

MORryde recommends using a high-quality, multipurpose, extreme pressure (EP) lithium complex grease for automotive wheel bearing use. It should be NLGI GC-LB certified and NLGI Grade 2. MORryde uses Kendall L-427 Super Blu #2.

JACKING UP A UNIT

The unit should always be jacked up at the frame of the trailer. Place safety stands near the front and rear of the trailer frame. To perform suspension work, the unit should be raised so that the tires are approximately 1" off the ground. In an emergency, it is permissible to place a jack under the I.S. beam assembly under the rubber springs to change a tire.

1 - Bottleneck jack placement

2 - Floor jack placement

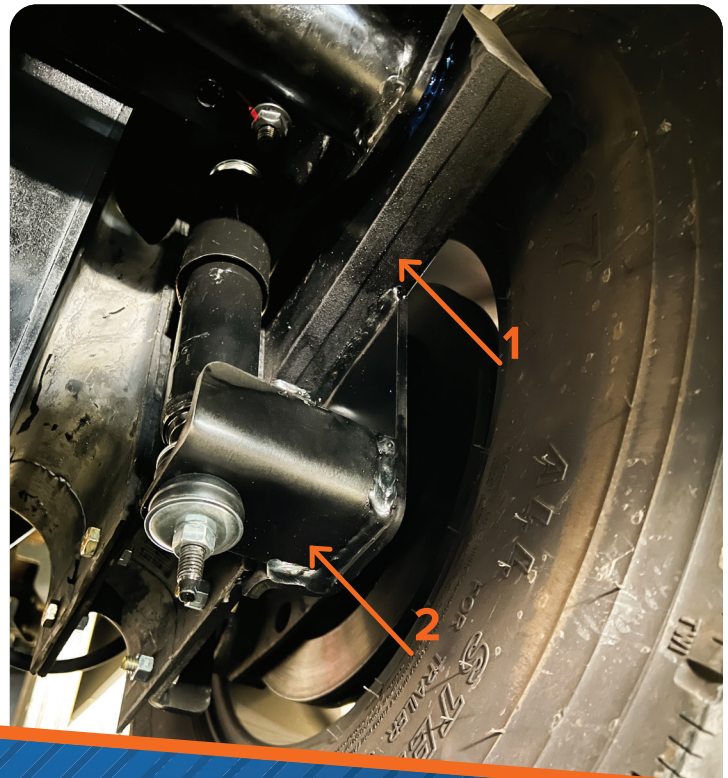

Above. Beyond. Always.

574.293.1581
www.MORryde.com

INDEPENDENT SUSPENSION SYSTEM

SERVICE PROCEDURES

HEIGHT ADJUSTMENT

The I.S. system provides trailer height adjustment. There is an extra set of holes in the hanger assembly that can be used to adjust the height of the trailer. The trailer can also be adjusted from side to side to compensate for uneven loads. The adjustment holes are located where the rubber springs bolt to the frame. Installing the rubber springs into the lower set of holes will raise the trailer by 1".

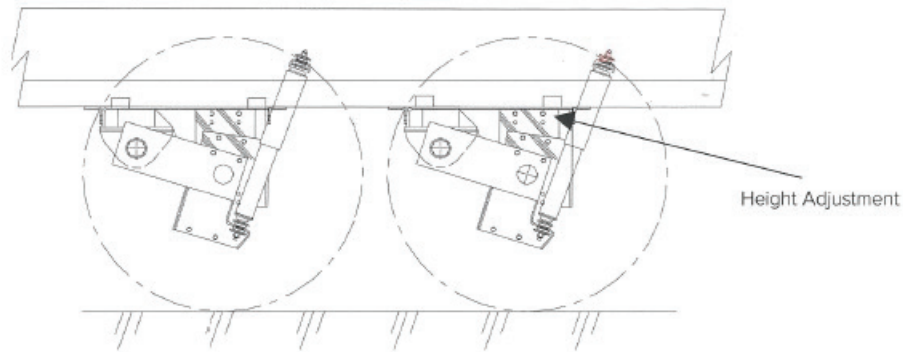

RUBBER SHEAR INSPECTION, DEFLECTION & REPLACEMENT

INSPECTION

MORryde rubber springs are made of a special formulation of natural rubber and are bonded to steel plates. There are two unlikely problems that may occur with MORryde rubber springs:

1. **Bond failure:** This condition is apparent when the rubber separates or delaminates from the metal plate.
2. **Rubber failure:** This condition is apparent when the rubber tears or rips apart in the middle of the rubber spring, but not against the plates.

The rubber springs on your I.S. system should be periodically inspected for any tears or cracks. If a rubber spring has a 3" wide **AND** 3/4" deep crack or tear, it should be replaced. A flat tool such as a putty knife can be used as a probe to check this. If the knife can be inserted into the rubber to a depth of 3/4" or more **AND** at a width of 3" or more, the rubber should be replaced.

INDEPENDENT SUSPENSION SYSTEM

RUBBER SHEAR SPRING PROCEDURES

NOTE: It is normal to see rubber spring weather checking, or small surface cracks in the rubber. Weather checking does not require a rubber spring replacement.



This is the rubber area that should be inspected.

DEFLECTION

If you're experiencing issues with ride quality, you can determine the rubber shear spring deflection by following the steps below.

1. Park the vehicle on level ground.
2. Measure Dimension A: From the ground to the bottom edge of the rubber spring at the hanger.
3. Measure Dimension B: From the ground to the center mold line of the outer rubber spring plate at the beam assembly.
4. Use the formula below to determine inches of rubber spring deflection.

DEFLECTION FORMULA

1. Dimension **A** - Dimension **B** = C
2. 5 - C = Deflection

NOTE: The measurements above should only be taken while hooked up to your tow vehicle for accuracy.

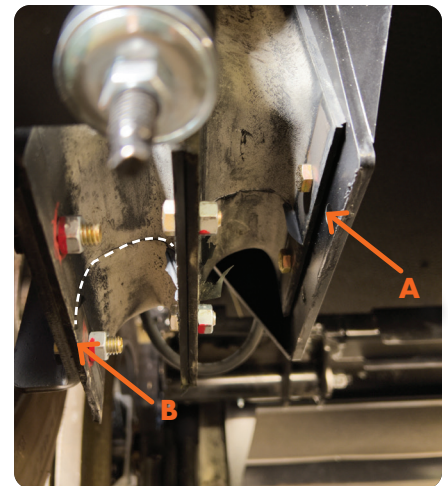
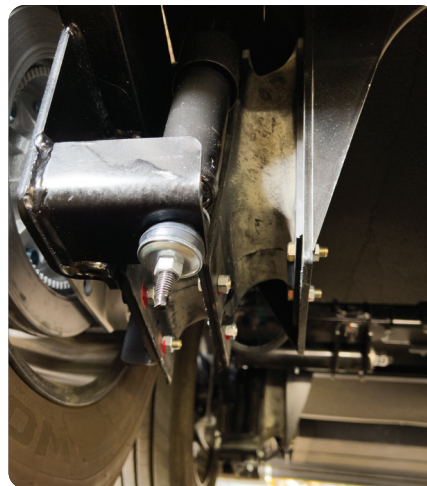

Above. Beyond. Always.

574.293.1581
www.MORryde.com

INDEPENDENT SUSPENSION SYSTEM

RUBBER SHEAR SPRING PROCEDURES

REPLACEMENT

VIDEO: MORryde INDEPENDENT SUSPENSION SPRING CHANGE PROCEDURE



1. Jack the trailer on the frame until the wheel is completely off the ground.
2. Place jack stands under the frame.
3. Disconnect the bottom end of the shock absorber.
4. Place a floor jack under the brake drum/rotor.
5. Remove the top two bolts from the beam assembly first.
6. Remove the bottom two bolts. The springs are slightly twisted, so you may have to use a line-up pin in one bolt hole to remove the last bolt.
7. Lower the beam assembly using the floor jack.
8. Remove the four bolts on the hanger assembly.
9. Replace with new spring or adjust the old one to desired settings.
10. Raise the floor jack under the drum/rotor until you line up one of the bottom holes. Then put a bolt in and finger tighten the nut.
11. Remove the floor jack.
12. One side of the rubber spring will be below the beam assembly. Place the floor jack under that corner of the spring and jack it up until it is flush with the steel plate. It may be necessary to tap the top of the spring with a hammer.
13. Put the line-up pin in the other bottom bolt hole and use it to line up the holes on the top two bolts. Finger tighten the nuts.
14. Remove the line-up pin and put the last bolt in. Finger tighten the nut.
15. Tighten all the nuts, torque to 40 ft-lbs, and reinstall the shock mount, tightening the nut until the rubber bushing bulges to the diameter of the washer.
16. Go to next wheel and repeat steps 3-15.
17. Reinstall the wheel and lugs.
18. Jack up the frame and remove the jack stands.
19. Torque the lug nuts to the manufacturer specifications.

ALIGNMENT PROCEDURES

The design of the I.S. system allows for automotive style toe and camber wheel alignment. This allows you to effectively manage tire wear under normal towing conditions. Wheel alignment should be done with equipment that is designed for multiple axle trailers. The I.S. system is adjustable for both toe and camber. Any alignment shop capable of aligning full-size trailers should be able to handle the job. MORryde uses laser alignment equipment. There are four bolts and one torque bracket per wheel that allow for these adjustments. Refer to the following directions for proper tow and camber alignment procedures.

VIDEO: INDEPENDENT SUSPENSION ALIGNMENT PROCEDURE



NOTE: Always adjust the camber first followed by the toe.

INDEPENDENT SUSPENSION SYSTEM

ALIGNMENT PROCEDURES

ADJUSTING CAMBER

1. Connect the alignment machine and level the unit on the alignment turntables.
2. Loosen the highlighted bolt and nut assembly.
3. If the camber is negative, add a shim(s) to the outside of the torque bracket.
4. If the camber is positive, add a shim(s) to the inside of the torque bracket.
5. A 1/4" shim will change the camber approximately 1°. Shim stack up should not exceed 1/2".
6. Refer to the **Torque Chart** section of this document to tighten bolts to the correct torque values.

NOTE: The unit will need to be raised to add camber.

ALIGNMENT SPECIFICATIONS

Camber (+.20° to +.50° loaded) or
(+.30° to +.60° unloaded)
Toe (+/- .07°)

CAMBER SHIM SPECIFICATIONS

Shims are available in three sizes:
1/4", 1/8", and 1/16"

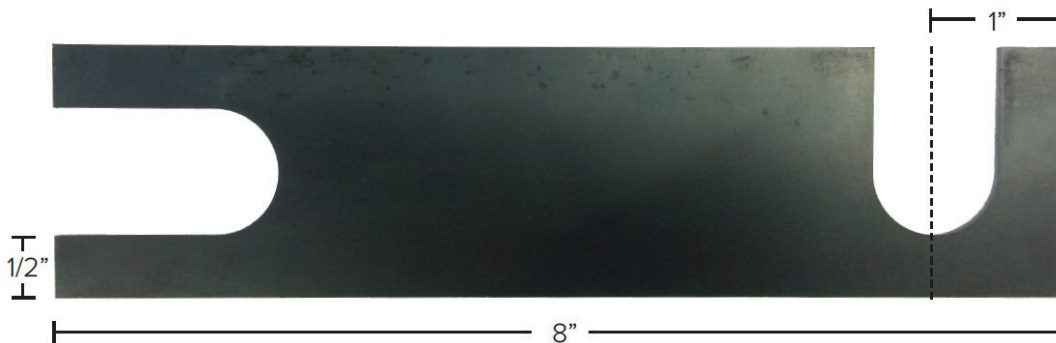
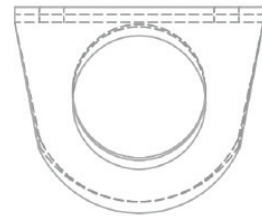
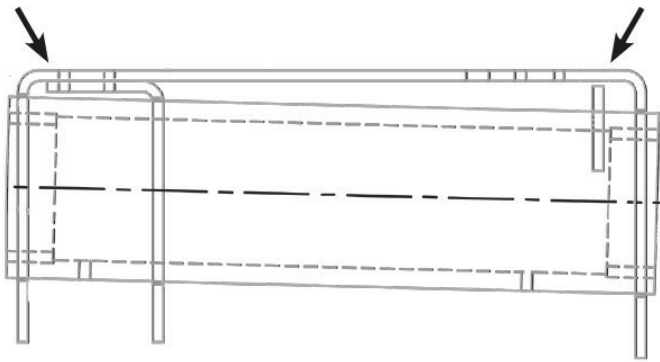

Above. Beyond. Always.

574.293.1581
www.MORryde.com

INDEPENDENT SUSPENSION SYSTEM

ALIGNMENT PROCEDURES

ADJUSTING TOE

1. Connect the alignment machine and level the unit on the alignment turntables.
2. Loosen the highlighted bolt and nut assembly.
3. Adjust the torque bracket assembly to obtain the correct toe readings on the alignment machine.
4. Refer to the **Torque Chart** section of this document to tighten the bolts to the correct torque values.

NOTE: Toe adjustments can be eased by the use of a “port-a-power” or large adjustment bar.

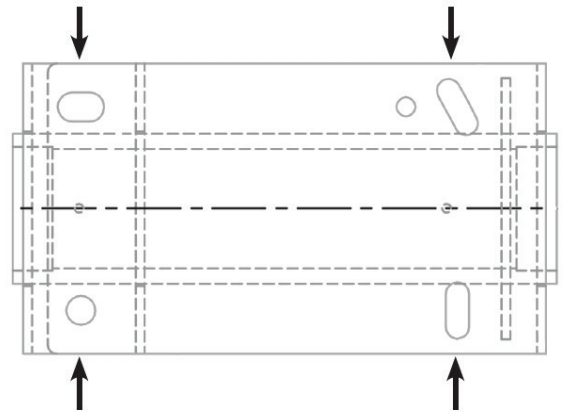

SHOCK ABSORBER MAINTENANCE & REPLACEMENT

Monroe hydraulic shocks are standard equipment on all I.S. Systems. Shock absorbers of this type should be checked every 10,000 miles to make sure they are functioning properly, bushings are not worn, and the dust cover has not been damaged by debris from the road. The shocks should be periodically inspected for oil leaks. If a shock absorber is leaking, fails to operate, or develops an unusual noise, the shock absorber should be replaced. Consult with MORryde directly for replacements by calling the Parts Department at **574-293-1581** or emailing parts@morryde.com.

REPLACEMENT

To replace a shock absorber, refer to the figure (page 11) and instructions below:

1. Remove the fasteners.
2. Remove the shock absorber.
3. Install the new bushings on the new shock absorber.
4. Torque the nuts until the rubber bushings bulge to the diameter of the washers.

INDEPENDENT SUSPENSION SYSTEM

SHOCK ABSORBER MAINTENANCE & REPLACEMENT

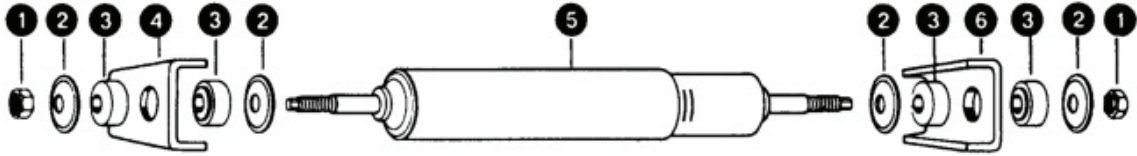

- | | |
|-------------------|-------------------------------------|
| 1. Fastener nut | 4. Clip welded to the trailer frame |
| 2. Washer | 5. Shock absorber |
| 3. Rubber bushing | 6. Clip welded to the beam assembly |

REPLACEMENT OF BEAM ASSEMBLY

The beam assembly attaches the wheel and rubber suspension to the hanger assembly, which is welded to the frame of the unit. Should a beam and/or spindle become damaged and need replacement, follow the steps below.

1. Jack up the unit. (See the **Procedures for Jacking Up a Unit** subsection under the **Service** section of this document.)
2. Remove the wheel.
3. Remove the drum or disc brake components.
4. Remove the rubber shear springs from the beam assembly.
5. Disconnect the shock from the lower shock mount on the beam assembly.
6. Remove the nuts and washer at the end of the journal bar (toward the inside of the frame).
7. Pull out the beam assembly.
8. Slide in the new beam assembly. (Torque bracket bushings should be replaced if they are damaged or worn).
9. Reconnect the shock to the beam assembly, then reinstall the rubber spring assembly, and the brake components.
10. Reinstall the wheel.
11. Torque lugs according to the OEM specifications.



Above. Beyond. Always.

574.293.1581
www.MORryde.com

INDEPENDENT SUSPENSION SYSTEM

TORQUE CHART

BOLT SIZE	GRADE 5* (FT-LBS)	GRADE 8* (FT-LBS)
3/8-16	X	40
1/2-13	X	90
5/8-11	X	170
3/4-10	250	X

See manufacturer's specifications when torquing lug nuts. If manufacturer specifications cannot be found, use the following guidelines:

1/2": 100 FT-LBS	9/16": 140 FT-LBS	5/8": 150 FT-LBS
------------------	-------------------	------------------

**Torque values must be verified with a torque wrench. A calibrated pneumatic impact wrench is not an acceptable substitute.*

> Re-torque lug nuts at 100 miles and 200 miles

BRAKE CONTROL SETUP

The first time you are connected to your trailer after our install, set the power to 6 with no boost. Find a dry and level paved surface and get up to 25mph and fully apply the manual knob. If your brakes LOCK UP, turn down the power. If your braking wasn't sufficient, turn up the power. Repeat this process until you get to a comfortable point with the power, or just before the brakes lock up. The main idea is comfort of the driver with the trailer and that the trailer should NOT stop your truck.

Note: Please refer to the Tekonsha P3 Owner's Manual for more information.

WARRANTY INQUIRIES

For further information or for questions regarding our product Warranties, please contact MORryde directly for service at **574-293-1581** or by emailing **parts@morryde.com**.

INDEPENDENT SUSPENSION SYSTEM

LIMITED WARRANTY

We, MORryde, Inc., 1966 Sterling Avenue, P.O. Box 579, Elkhart, IN 46516 ("MORryde"), warrant to you, the original first purchaser of new MORryde rubber suspension system ("Product"), for a period of five (5) years from the date of original first purchase, or use or operation for a distance of fifty thousand (50,000) miles, whichever occurs first ("Warranty Period"), that the Product is free of defects in material or workmanship under normal use and service and will meet or exceed all of our advertised written specifications, excepting items and uses excluded from this Warranty. Labor charges are covered for 12 months from the original date of purchase.

Examples of Items and Uses Excluded from Warranty

We are not responsible for, and this Warranty does not apply to, (a) any part of the Product that is defective or damaged due to abuse; misuse; neglect; accident; unauthorized replacement, repair, parts, or modification; (b) Products with no proof of mileage, or date of purchase; (c) duplication of repair due to faulty diagnosis or workmanship of others; (d) incorrect installation of any part of the Product, including but not limited to, incorrect torque on bolts; (e) loading the Product or any part of it beyond our rated load capacity; (f) towing expenses, freight charges, transportation expenses, telephone, telegraph or other communication expense, overtime or holiday labor, downtime or owner's layover expenses such as meals and lodging; (g) re-springing suspension for ride adjustment; (h) failure of another component which results in our Product's failure; (i) YOU ARE NOT ENTITLED TO RECOVER FROM US ANY CONSEQUENTIAL OR INCIDENTAL DAMAGES RESULTING FROM ANY DEFECT IN OUR PRODUCT. THIS INCLUDES ANY DAMAGE TO ANOTHER PRODUCT OR PRODUCTS RESULTING FROM SUCH A DEFECT. SOME STATES DO NOT ALLOW THE EXCLUSION OR LIMITATION OF INCIDENTAL OR CONSEQUENTIAL DAMAGES, SO THE ABOVE LIMITATION OR EXCLUSION MAY NOT APPLY TO YOU. EXCEPT AS OTHERWISE SPECIFICALLY DESCRIBED IN THIS WARRANTY, WE MAKE NO OTHER WARRANTY, EXPRESS OR IMPLIED, IN CONNECTION WITH OUR PRODUCT, INCLUDING ANY WARRANTY OF MERCHANTABILITY OR FITNESS FOR A PARTICULAR PURPOSE.

What We Will Do

We will remedy any defect in materials or workmanship by authorized repair or replacement. Warranty work can only be performed at our factory or authorized service centers. We will remedy the defect within a reasonable time after receipt of the defective product at the factory or authorized service center. All our expenses in remedying the defect will be borne by us, including labor and material.

How to Obtain Warranty Service

You must notify us of your need for warranty service not later than thirty (30) days after expiration of the Warranty Period. We will notify you of the nearest authorized service center to which you should deliver the Product. Corrective action will be taken within a reasonable time of the date of receipt of the defective Product by us at the factory, or at one of our authorized service centers. For further information about our factory or authorized service centers, write or call at the address or telephone number listed below.



Above. Beyond. Always.

574.293.1581
www.MORryde.com

Alteration of this Warranty

NO PERSON HAS THE AUTHORITY TO ENLARGE, AMEND OR MODIFY THIS WARRANTY. THE WARRANTY IS NOT EXTENDED BY THE LENGTH OF TIME WHICH YOU ARE DE-PRIVED OF THE USE OF THE PRODUCT. REPAIRS AND REPLACEMENT PARTS PROVIDED UNDER THE TERMS OF THIS WARRANTY SHALL CARRY ONLY THE UNEXPIRED PORTION OF THIS WARRANTY.

Other Legal Rights

This warranty gives you the specific legal rights, and you may also have other rights which vary from state to state. No action to enforce this Warranty shall be commenced later than ninety (90) days after expiration of the Warranty Period.

Changes in Our Products

We reserve the right to change the design of any part of the Product, make additions or improvements to it from time to time, without notice and with no obligation to make corresponding changes or improvements to Products previously manufactured.

For more information on MORryde suspension system warranties, visit our website at www.morryde.com/warranty.

PLEASE DIRECT ALL CORRESPONDENCE TO:

MORryde International

P.O. Box 579

Elkhart, IN 46516

Phone: (574) 293-1581

Fax: (574) 294-4936

Email: parts@morryde.com

www.morryde.com



INDEPENDENT SUSPENSION SYSTEM

At MORryde, we have a passion for solving problems. Whether we're fabricating custom solutions, modifying a commercial chassis, or creating our innovative products, we answer to a wide range of markets and deliver on a variety of needs. At MORryde, it's simply about doing MORE for our customers, and it doesn't stop at the sale. We stand behind our products, believing in quality first, service always. No matter the issue, we'll be the first to respond and the last to be satisfied. In short, we build better — together.



Above. Beyond. Always.

I.S. System | Version 17

574.293.1581
www.MORryde.com