

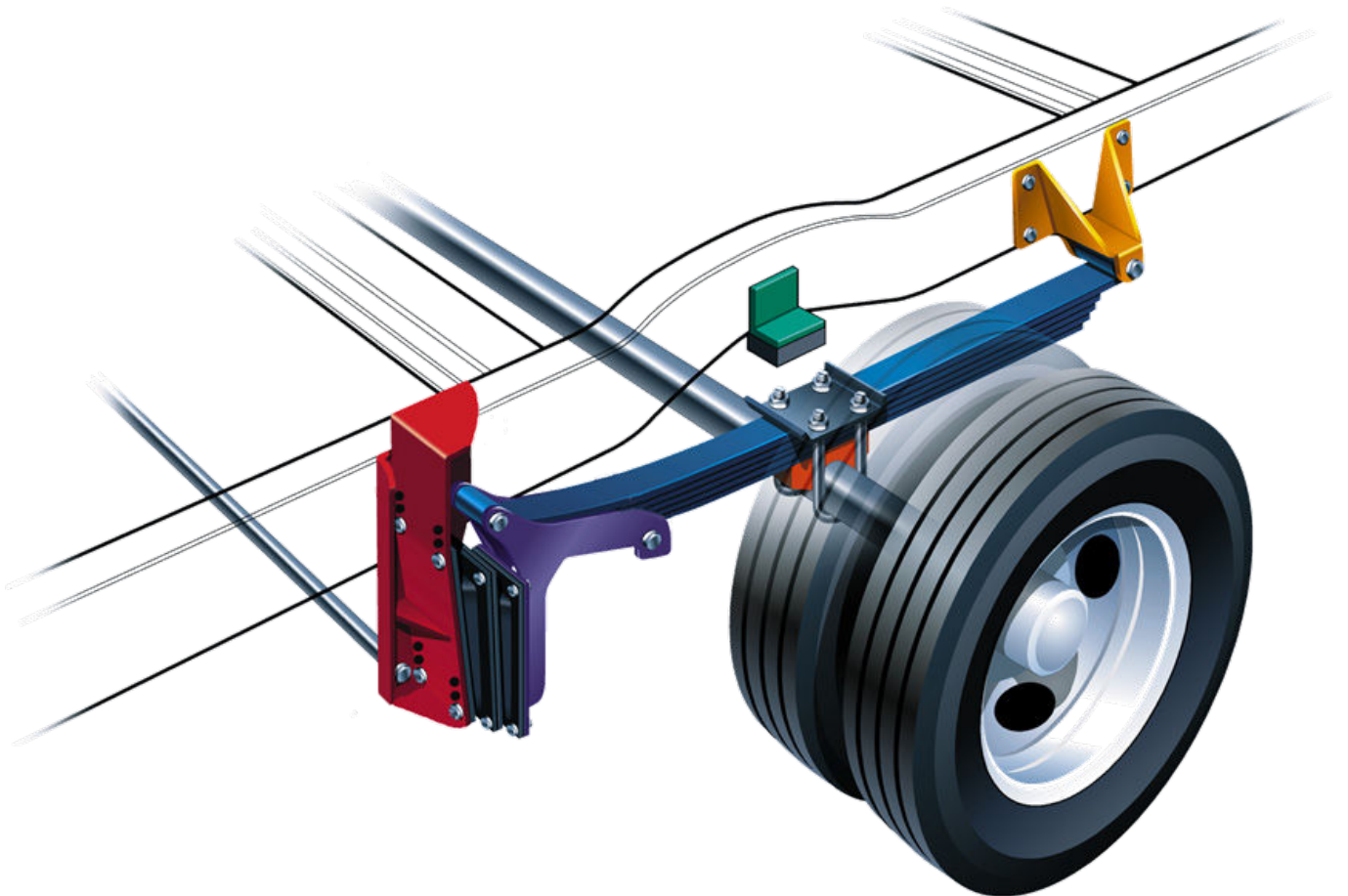

Above. Beyond. Always.

# RL (Rubber Leaf) Suspension System Owner's Manual



# RL Suspension System

## CONTENTS

Introduction.....	2
Parts Listing.....	3
Rubber Shear Spring Inspection.....	4
Height Adjustment.....	4
Measuring Rubber Shear Spring Deflection.....	5
Measuring Rubber Spring Carrier Travel.....	5
Checking Rubber Shear Spring Stability.....	6
Basic Trouble-shooting.....	6
Warranty.....	7

# INTRODUCTION

Congratulations on your purchase of the MORryde “RL” Suspension System\*. The system installed on your vehicle utilizes rubber shear springs that work in conjunction with the chassis drive axle steel leaf springs. These double-eye leaf springs may be either multi style, or taper style (Fig. 1). The RL system has replaced the leaf spring hanger and shackle with a MORryde hanger, spring carrier and rubber shear springs. (Fig. 2) The rubber shear springs isolate and absorb road shock and increase the dynamic axle travel. This provides you with:

- **A much smoother ride**
- **Improved handling and drivability**
- **Better protection of the vehicle from damaging road shock**
- **Less vibration**

The MORryde RL system is available for a wide variety of vehicle applications including:

- **Pickup Trucks**
- **Medium Duty Buses**
- **Limo Buses**
- **Motorhomes**
- **Paratransit Vehicles**
- **Specialty Vehicles**

Each RL system is designed specifically for the chassis of the vehicle that it is installed on. Maintenance to the RL system is very limited. This manual will outline general inspection and troubleshooting guidelines. Service manuals and instructions are provided with replacement parts in the unlikely event that service is required.

**Figure 1**

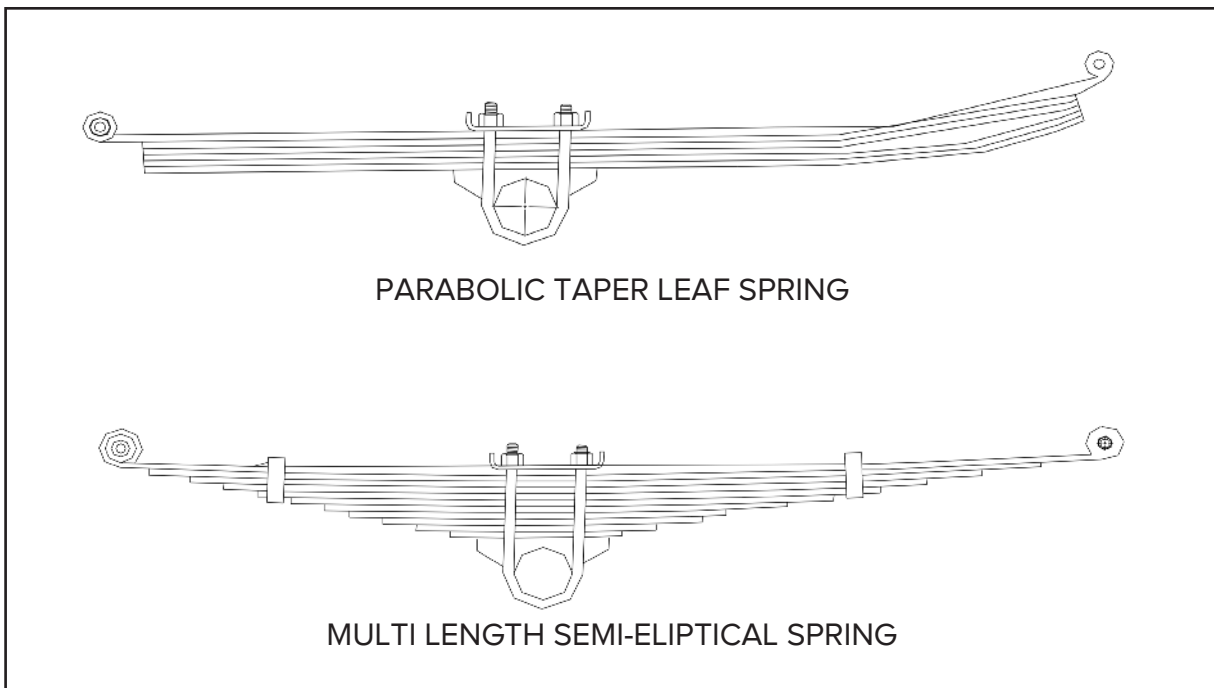

\* Made in the U.S.A. Patent Number 6,176,478

# PARTS LISTING

If you are in need of replacement parts, please reach out to us at (574) 293-1581 and ask for a MORryde Customer Service representative to assist you with your needs. To help ensure the correct parts are sent, the following information is necessary:

- **Year of unit**
- **Make of Vehicle (Ford, Chevy, etc.)**
- **Builder of Body**
- **Model**

If the rubber shear springs are being replaced, please locate the number on the side of the molded rubber. There are two different types of rubber shear springs:

- **Two blocks bolted together**
  - Possible spring numbers: 2, 3, 6, 7, 11, 30, or 35
- **Two blocks bonded together**
  - Possible spring numbers: 63, 75, 88, or 100

Below is a breakdown of the components in a typical MORryde RL Suspension System. Individual systems may vary in size, shape, and look. Not all systems have the exact parts shown below.

**Figure 2**

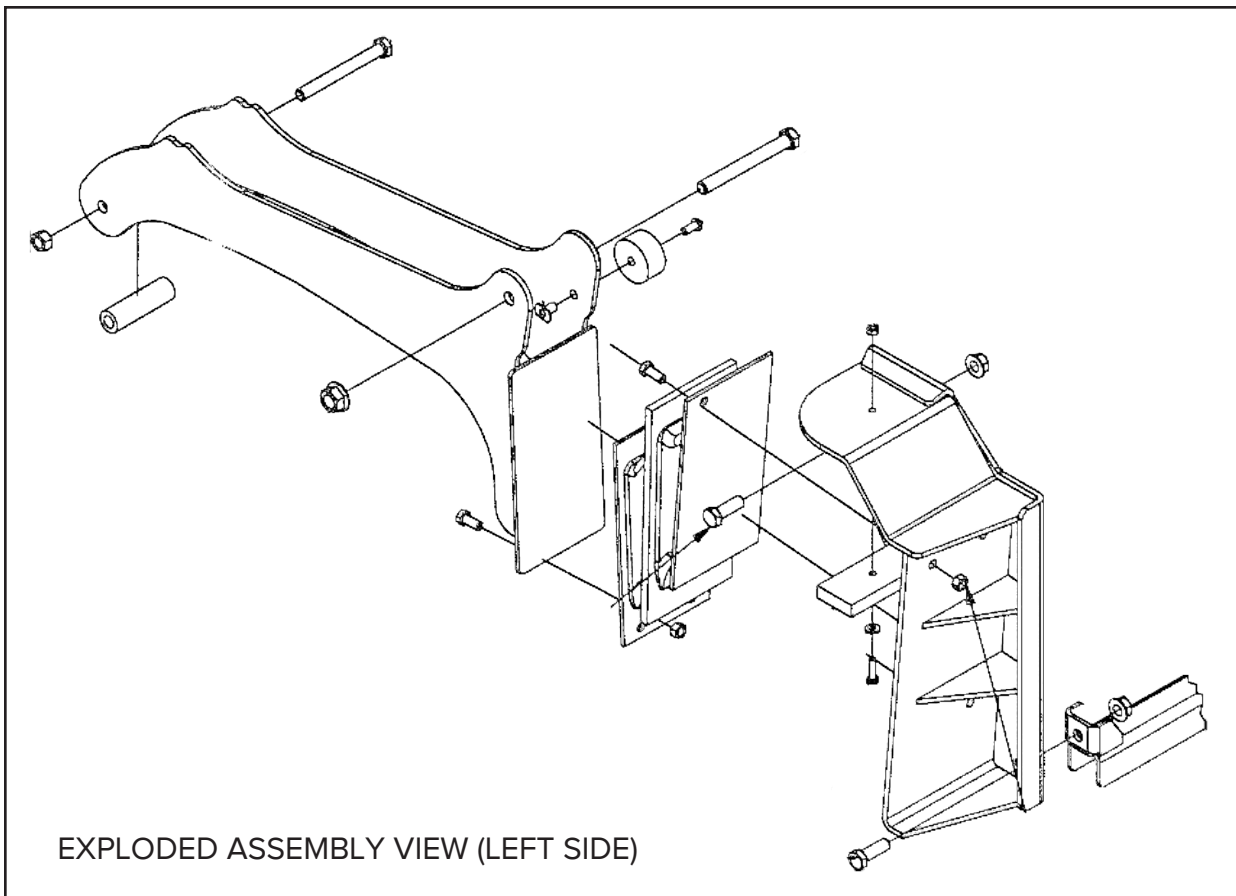

# TROUBLE-SHOOTING / MAINTENANCE CHECKS

## Rubber Shear Spring Inspection

The rubber springs (Fig. 3) should be periodically inspected for any tears or cracks. If a rubber spring exhibits a 3" long and 3/4" deep crack or tear, the rubber spring should be replaced. This can be checked by using a flat tool such as a putty knife. The putty knife can be used to probe the rubber spring in the affected area. If the knife can be inserted 3/4" deep, by at least 3" long, the spring rate of the spring is affected and should be replaced.

**Note:** *It is normal to see rubber spring weather checking, which is small surface cracks in the rubber. Weather checking does not require a rubber spring to be replaced.*

**Figure 3**

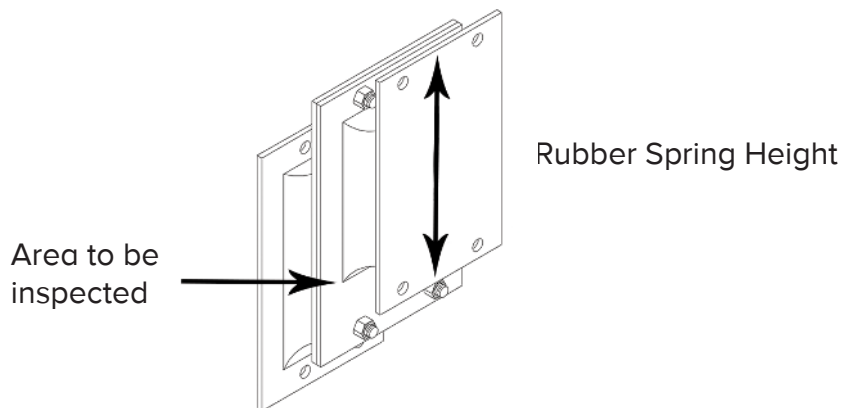

## Height Adjustments

The MORryde RL suspension system offers vehicle height adjustment. A series of holes is offered on the frame hanger assembly (Fig. 4). Depending on your system, there may be 2, 3, or 4 sets of mounting holes positioned at one inch increments. As the rubber springs are re-indexed to a lower set of mounting holes, the rear of the vehicle will be raised. This feature may be useful to level a vehicle as it is permissible to have the rubber springs positioned in different holes from side to side.

**Figure 4**

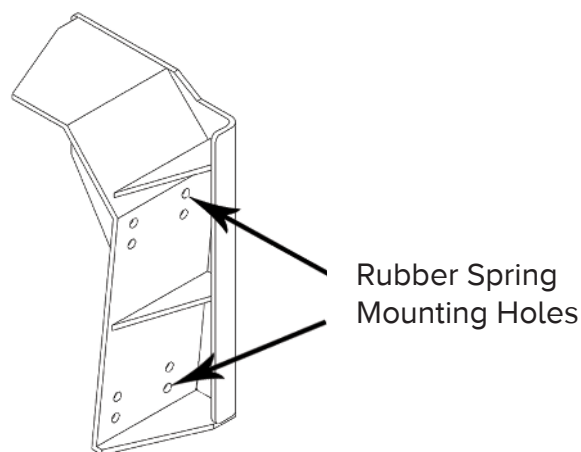

## Measuring Rubber Spring Deflection

Park the vehicle on level ground. Measure Dimension A, ground to bottom edge of the rubber spring at the hanger (Fig. 5). Measure Dimension B, ground to bottom edge the rubber spring at the spring carrier. Use the following formula to determine rubber spring deflection:

- **Step 1:** Dim. A - Dim. B = C
- **Step 2:** a) Rubber Spring Deflection = 5 - C  
b) Rubber Spring Deflection = 4 - C

Note: For step 2 use equation (a) if the rubber shear spring is 10 inches tall. Use (b) if the rubber shear spring is 8 inches tall. (See Fig. 3)

**Figure 5**

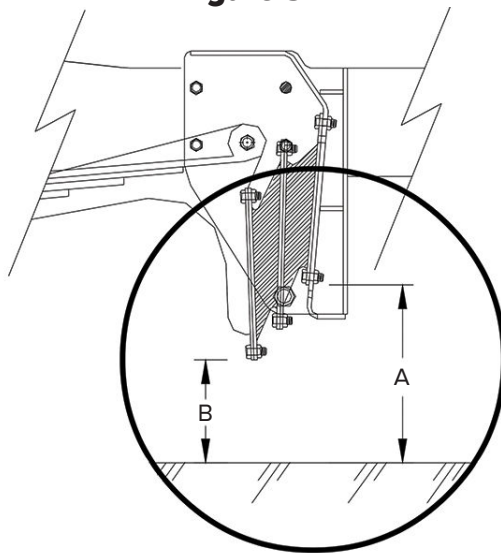

## Measuring Spring Carrier Travel

The spring carrier travel is defined as the vertical travel the spring carrier can move before the carrier strikes the top (limiter) of the hanger assembly at the rear spring eye. (See Fig. 6 Spring Carrier Travel- SCT).

**Figure 6**

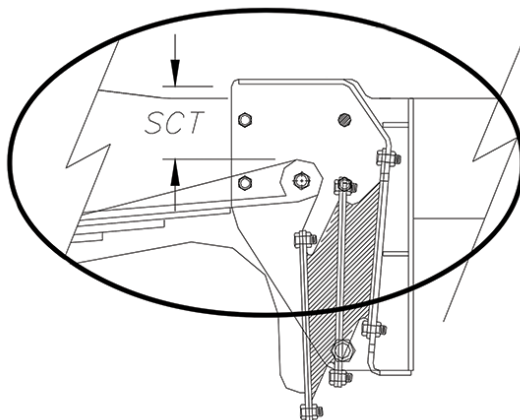

## **Basic Trouble-Shooting**

Problem / Symptom	Cause	Correction
<ul style="list-style-type: none"> <li>Spring carrier/spring eye bottoming on frame hanger limiter (see Fig. 6)</li> </ul>	<ul style="list-style-type: none"> <li>Torn rubber spring</li> <li>Rubber shear spring over deflected ( See Fig. 5)</li> <li>Not enough spring carrier travel</li> </ul>	<ul style="list-style-type: none"> <li>Replace rubber spring</li> <li>Replace rubber spring</li> <li>Re-index rubber spring to a lower hole setting in the frame hanger</li> </ul>
<ul style="list-style-type: none"> <li>Vehicle Leaning to one side</li> <li>NOTE: Your RL Suspension has built-in leveling adjustments to compensate for uneven loading. It is not always possible for the built-in adjustment to level the vehicle. Occasionally additional steel leaf springs are required, or a spacer block must be added to the axle</li> </ul>	<ul style="list-style-type: none"> <li>Torn rubber spring</li> <li>Rubber shear spring over deflected (See Fig. 5)</li> <li>Uneven loading</li> </ul>	<ul style="list-style-type: none"> <li>Replace rubber spring</li> <li>Replace rubber spring with stiffer durometer spring</li> <li>Re-index rubber spring to a different hole setting in the frame hanger</li> <li>Add a spacer block or an additional steel leaf spring</li> </ul>
<ul style="list-style-type: none"> <li>Excessive noise</li> </ul>	<ul style="list-style-type: none"> <li>Improper tire pressure</li> <li>Torn rubber shear spring</li> <li>Improper hitch weight</li> </ul>	<ul style="list-style-type: none"> <li>Replace lateral control parts</li> </ul>

# LIMITED WARRANTY

## Summary of Warranty

We, MORryde, Inc., 1966 Sterling Avenue, P.O. Box 579, Elkhart, Indiana 46516, warrant to you, the original first purchaser of new MORryde rubber suspension system (“Product”), for a period of three (3) years from the date of original first purchase, or use or operation for a distance of seventy thousand (70,000) miles, whichever occurs first (“Warranty Period”), that the Product is free of defects in material or workmanship under normal use and service and will meet or exceed all of our advertised written specifications, excepting items and uses excluded from this Warranty. Labor charges are covered for 12 months from date of purchase of the vehicle on a warranty item in which coverage is pre-approved by MORryde.

## Warranty Information

For further details regarding the specifications of your MORryde RL suspension warranty, please contact a MORryde Service Representative at the number below.

**PLEASE DIRECT ALL CORRESPONDENCE TO:**

**MORryde International  
P.O. Box 579  
Elkhart, IN 46516  
Phone: (574) 293-1581  
Fax: (574) 294-4936  
Email: [service@morryde.com](mailto:service@morryde.com)  
[www.morryde.com](http://www.morryde.com)**



**Above. Beyond. Always.**