



S U S P E N S I O N

QUALIFICATION GUIDE

STEP 1A

If axles are Over Slung (OS) as shown in figure 1, ALL frame hangers need to be a minimum of 3 1/4" tall.

STEP 1B

If axles are Under Slung (US) as shown in figure 2, ALL frame hangers need to be a minimum of 4 1/4" tall.

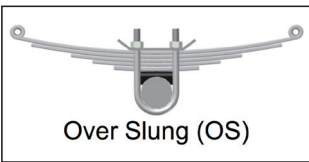

figure 1

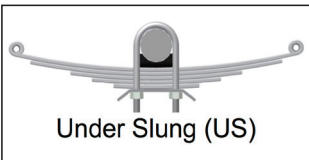

figure 2

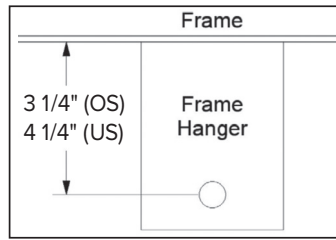

figure 3

STEP 2

Equalizer hanger width MUST be 3" and 1 1/2" from edge of hanger to center of hole. If wider, trim hanger as shown in figure 4.

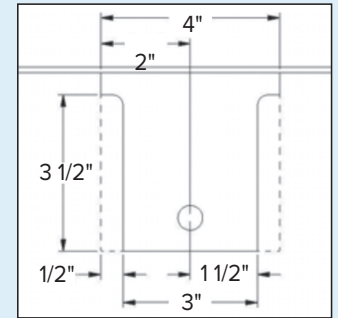

figure 4

STEP 3

If frame hanger has height adjustment, the AllTrek 4000™ must be installed in the tall ride height (lowest hole) OR the taller setting(s) (lowest holes) could be cut off—be sure to leave the same amount of material below the installation hole as there was below the bottom hole.

STEP 4

A 1 3/4" wide double-eye leaf spring must be used. The AllTrek 4000™ is not compatible with slipper-style leaf springs.

STEP 5

Verify the frame hanger spread (FHS) as shown in figure 5 meets the minimum measurement required given the variables in the table below.

Wheelbase	Leaf Spring Length (at Design Load)	Minimum FHS Measurement	
		Tandem	Triple
31"	24"	54 7/8"	N/A
33"	26"	58 7/8"	91 7/8"
35"	26"	60 3/4"	95 3/4"

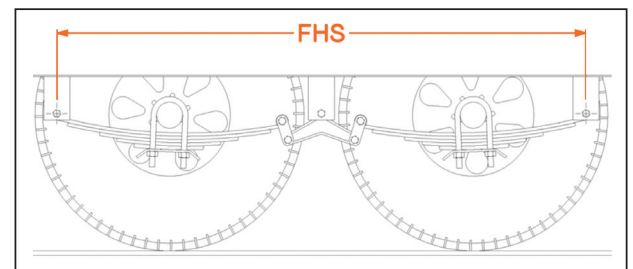

figure 5

STEP 6

Shackle links that measure 2 1/4" from hole center to hole center must be used. The only exception is for units with equalizer hangers that are at least 4 1/4" tall AND the axles are overslung. In this case, either the 2 1/4" or 3 1/8" shackle links can be used.

STEP 7

A straight axle, not a drop axle, must be used.

STEP 8

A minimum of a 15" rim must be used with an OS axle.
A minimum of a 16" rim must be used with an US axle.

STEP 9

Take the following measurements:

- _____ (A) Distance from the side of the tire to the side of the frame hanger.
A minimum of 1 11/16" is required.
- _____ (B) Distance from the top of the tire to the bottom of the floor at load.
A minimum of 3" is required. It is best practice to utilize a bump stop on the frame of the trailer for the axle assembly to bottom into before the tire contacts the floor.
- _____ (C) Distance from the closest part of the axle assembly to the underside of the frame at load. A minimum of 2 1/2" is required.
- _____ (D) Height of the stock equalizer from the center of the top bolt hole to the center of the bottom bolt hole.

figure 6

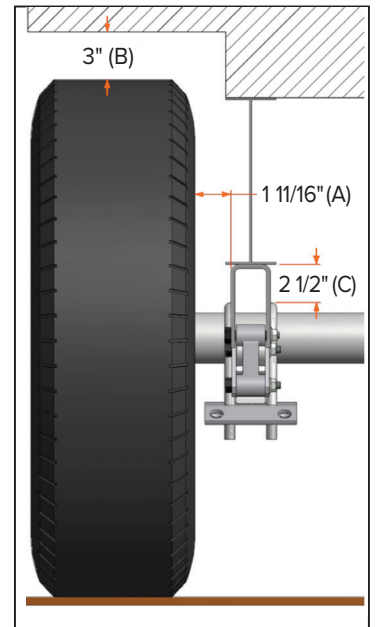
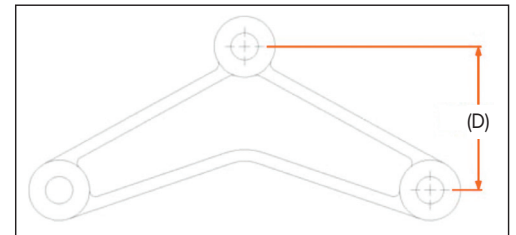

figure 7



STEP 10

It is important to verify that the installation of the **AllTrek 4000™** will not affect the above clearance requirements.

OPTION 1:

If your measurement (D) is **greater than 3"**,
perform the following calculations:

$$\frac{\text{Measurement (D)} - 3''}{2} = (X)$$

Subtract Measurement (X) from Your Measurement (B).

(B) - (X) = must be a minimum result of 3"

Subtract Measurement (X) from Your Measurement (C).

(C) - (X) = must be a minimum result of 2 1/2"

OPTION 2:

If your measurement (D) is **less than 3"**,
perform the following calculations:

$$\frac{3'' - \text{Measurement (D)}}{2} = (Y)$$

Add Measurement (Y) to Your Measurement (B).

(B) + (Y) = must be a minimum result of 3"

Add Measurement (Y) to Your Measurement (C).

(C) + (Y) = must be a minimum result of 2 1/2"

* Triple axle **AllTrek 4000™** cannot be used with Correct Track.

* Triple axle **AllTrek 4000™** cannot have items hanging down under the frame between the equalizer hangers.

* If you have boxed in or aftermarket welded frame hangers, the triple axle **AllTrek 4000™** *will not* work for you.



Above. Beyond. Always.

574.293.1581 • www.MORryde.com